



Department of Civil Engineering

- **Vision:** “To impart quality technical education beneficial to industry and the society in the field of Civil Engineering.”.
- **Mission:**
 - To arrange academic and technical expertise.
 - To improve the practical knowledge of the student as per current scenario of industry.
 - To make the students socially and ethically responsible.

Assignment No :- 01

Subject : EAC

Topic Name :- Fundamental Of Estimating And Costing

Subject code: 22503

Course Outcome : CO501.1

Q.1. Define Estimating & Costing.

Q.2. State mode of measurement for following items of work as per I.S.1200 –

- (i) Inspection chamber
- (ii) Ironwork in truss
- (iii) Timbering of trenches
- (iv) PCC in foundation.

Q.3. Explain the Role And Responsibility Of Estimator.

Q.4. state the desired accuracy in taking measurement of work as per IS 1200.

Q.5. Explain the rules for deduction of opening in masonry and plastering work as per I.S.1200.

Q.6. Prepare checklist of items of work for framed structure.

Q.7. State the unit of measurement for following.

- i) Tile flooring ii) Barbed wire fencing iii) Formwork iv) W/C pan.

Q.8. Rule out measurement sheet and abstract sheet.

Q.9. Give Difference Between Revised Estimate and Supplementary Estimate.

Date of Submission :-

Assign By :- Ms. Shubhada Deshmukh



Department of Civil Engineering

- **Vision:** “To impart quality technical education beneficial to industry and the society in the field of Civil Engineering.”
- **Mission:**
 - To arrange academic and technical expertise.
 - To improve the practical knowledge of the student as per current scenario of industry.
 - To make the students socially and ethically responsible.

Assignment No :- 02

Subject : EAC

Topic Name :- Approximate Estimates

Subject code: 22503

Course Outcome : CO501.2

Q.1. Define Approximate Estimate.

Q.2. Prepare the approximate estimate of residential building having plinth area 900sqm. If the cost of construction of similar existing structure in locality is Rs.7200000 for plinth area of 1200sqm

Q.3. State any four purposes of preparing approximate estimate

Q.4. Suggest the method of approximate costing for-

i. Steel bridge

ii. Highway and Roads

iii. RCC Retaining Wall

iv. Irrigation Canal

Q.5. The plinth area of proposed building is 400 sq.m. The known cost of construction for similar structure is Rs. 19,35,000 having plinth area 225 sq.m. Calculate approximate cost of proposed building.

Q.6. Prepare the approximate estimate of a bridge having 4 spans of 42 m each using following data cost of existing bridge Rs. 1.5 or existing bridge having 3 spans of 50 m each.

Date of Submission :-

Assign By :- Ms. Shubhada Deshmukh



Department of Civil Engineering

- **Vision:** “To impart quality technical education beneficial to industry and the society in the field of Civil Engineering.”.
- **Mission:**
 - To arrange academic and technical expertise.
 - To improve the practical knowledge of the student as per current scenario of industry.
 - To make the students socially and ethically responsible.

Assignment No :- 03

Subject : EAC

Topic Name :- Detailed Estimate and Provision

Subject code: 22503

Course Outcome : CO501.3

1. State and explain data required for preparing detailed estimate.
2. State the meaning of work charged establishment and give its general percentage.
3. Distinguish between Long Wall - Short Wall method and center line method (any- four points of differences)
4. Explain the following terms in brief
 - (i) Contingencies
 - (ii) Provisional Sum
5. Explain the term - 'Spot items' and give any two examples of it.
6. Calculate the quantity of excavation for foundation for structure shown in Figure No. 1.
7. Calculate the quantity of BBM in CM 1:6 for structure shown in Figure No. 1

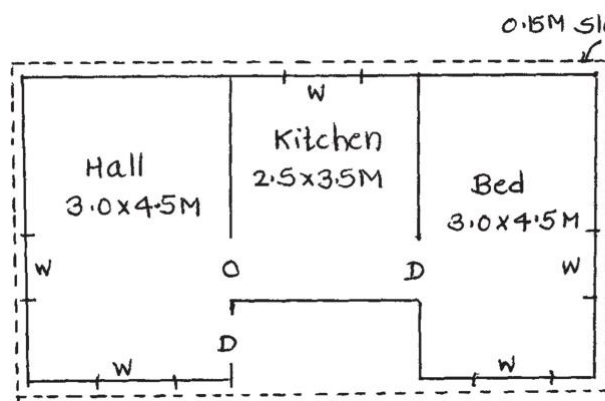

Line Plan

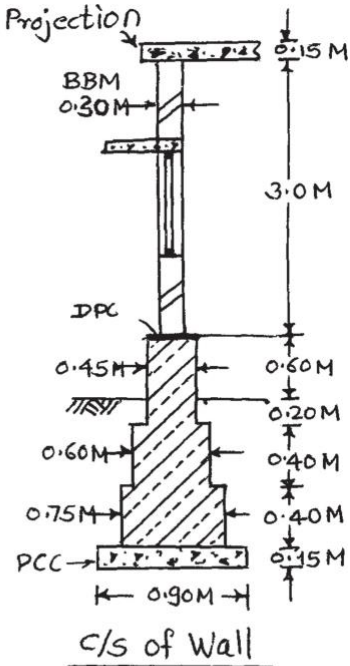

(Not to Scale)

- 8 Prepare a face sheet for the detailed estimate of residential building with following data
- | | | |
|------|--------------------------|---------------|
| i) | Civil construction cost | Rs. 1165300/- |
| ii) | Contingencies | 5% |
| iii) | Work charged established | 2% |
| iv) | Electrification | 8% |
| v) | Water supply arrangement | 5% |
| vi) | Sanitary arrangement | 5% |

Date of Submission :-

Assigned By :- Ms. Shubhada Deshmukh



Department of Civil Engineering

- **Vision:** “To impart quality technical education beneficial to industry and the society in the field of Civil Engineering.”.
- **Mission:**
 - To arrange academic and technical expertise.
 - To improve the practical knowledge of the student as per current scenario of industry.
 - To make the students socially and ethically responsible.

Assignment No :- 04
Topic Name :- Bar Bending Schedule

Subject : EAC
Subject code: 22503

Course Outcome : CO501.3

1. Draw section of two legged stirrup and state formula for finding total length of stirrup.
2. For a RCC framed structure, there are six columns of size 230 x 300 mm and length of column 3.60 m each.
Work out the total approximate quantity of steel required for all columns.
3. Work out the quantities of plain steel for the beam in following and prepare bar bending schedule-
 - (i) Overall length of beam - 4m long
 - (ii) Main bars - Total 04 Nos of 12mm dia, out of which, 02 bent up.
 - (iii) Size of beam - 230mm x 300mm
 - (iv) Anchor bars - 02 Nos. of 10mm dia.
 - (v) Stirrups - 6mm dia. at 150 mm c/c.
4. Work out quantity of steel for a circular column with following data.
 - (i) column : diameter - 600mm



- (ii) height = 4500mm
 - (iii) main steel : 8 bars - 12mm ϕ (Tor steel)
 - (iv) Links : 6mm ϕ (ms steel) @ 125mm c/c .
5. An RCC roof slab of overall size 6600 mm \times 2200 mm and thickness 150 mm is provided with 12 mm diameters main bars bent up alternately and placed at 150 mm c/c the distribution steel of 6 mm diameters is provided of 200 mm c/c . The all round cover is 15 mm. Find out the total quantity of plain steel. Prepare bar bending schedule.
6. A RCC simply supported beam of side 300 mm \times 650 mm is reinforced with four, 20mm diameters bars. The main bars are placed in one row and two are bent-up. Two anchor bars of 12mm diameters are provided to top and 6mm diameter stirrups are provided at 150 mm c/c . The span of beam is 5.6 m and end bearing is of 30cm. Calculate total quantity of mild steel reinforcement. Also prepare schedule of bars.

Date of Submission :-

Assigned By :- Ms. Shubhada Deshmukh



Department of Civil Engineering

- **Vision:** “To impart quality technical education beneficial to industry and the society in the field of Civil Engineering.”.
- **Mission:**
 - To arrange academic and technical expertise.
 - To improve the practical knowledge of the student as per current scenario of industry.
 - To make the students socially and ethically responsible.

Assignment No :- 05
Topic Name :- Rate analysis

Subject : EAC
Subject code: 22503

Course Outcome : CO501.4

1. State factors affecting rate analysis. Explain any one.
2. Calculate the quantities of materials required for -
 - (i) 60 Cu.M. Brick masonry in CM (1:6)
 - (ii) 100 Sq. M Pointing in CM (1:3)
3. Prepare rate analysis for 12mm plaster in CM 1:4
4. Prepare the rate analysis for U.C.R. masonry in CM(1:4) in foundation.



Department of Civil Engineering

- **Vision:** “To impart quality technical education beneficial to industry and the society in the field of Civil Engineering.”.
- **Mission:**
 - To arrange academic and technical expertise.
 - To improve the practical knowledge of the student as per current scenario of industry.
 - To make the students socially and ethically responsible.

Assignment No :- 06

Topic Name :- Estimating for Civil Engineering work

Subject : EAC

Subject code: 22503

Course Outcome : CO501.5

1. List any four softwares used for estimation in Civil Engineering.
2. Define
 - i. Lead and Lift
3. Calculate the volume of earthwork for a proposed road having formation width 10 m and side slopes 2:1 using mid sectional area method. Assume formation level as 115.50 m with no longitudinal slope.

Chainage	400	420	440	460	480	500
G.L. (m)	111.50	111.60	111.85	111.45	111.20	110.90

4. Calculate the quantities of earthwork in cutting and in banking for a portion of road with following data
 - i) Formation width of road is 12m.
 - ii) Formation level of starting chainage is 51-40m
 - iii) The road surface shall be given a falling gradient of 1 in 200.



iv) Side slope are 1V : 2 H in banking and 1V : 1.5H incutting.

Chainage	0	30	60	90	120	150	180
G.L	50.80	50.60	50.70	51.20	51.40	51.30	51.00

5. Calculate quantities of earth work for a road with following data.

Formating width - 10m.

Slope in cutting - 1.5 : 1 Slope in

banking - 2 : 1

Chainage in m	0	50	100	150	200
Ground level	500.00	499.30	498.45	494.90	494.00
Formation level	496.50	496.00	495.50	495.00	494.50

Calculate the quantity of excavation in standard.